

# Unsealed products

Unsealed products mentioned in this document are opto-semiconductors whose chip is exposed. Parts such as electrodes on the chip are not protected by an external enclosure and so require especially strict care during handling compared to ordinary products.

If the product comes with special usage, precautions on the delivery specification sheets, then be sure to strictly comply with those instructions.

## 1. What is an unsealed product?

An unsealed product is an unprotected item having no window material or similar enclosure and where the chip forming the photosensitive area or light emitting area is exposed to air. Unsealed products also include products with a temporarily attached window (including protective tape) during shipping, which is removed prior to use. Unlike ordinary packaged products, the chips on these unsealed products are not protected by an external enclosure and so require special care to prevent physical breakage or contamination. Bare chip products (wafers or diced chips) do not fall under unsealed products.

<Unsealed product examples>

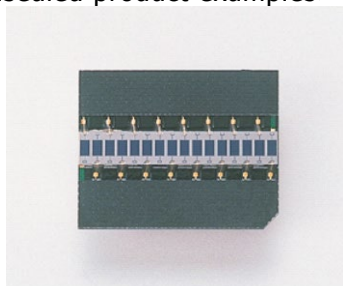

Type with wiring protected with resin

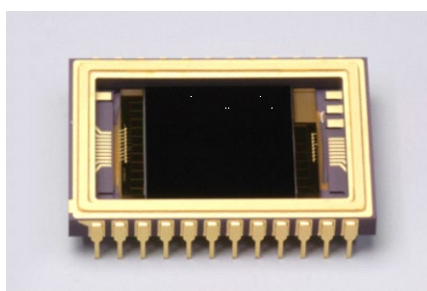

Ceramic type (windowless)

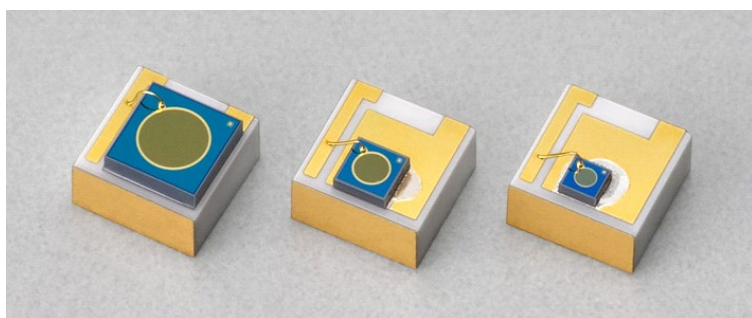

Chip carriers

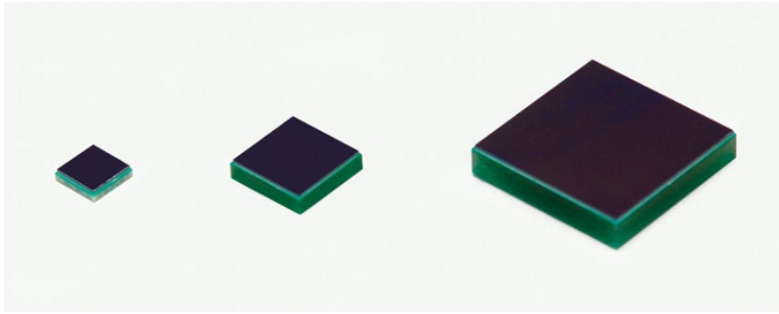

Bump connection types

## 2. Handling

### (1) Usage environments

- Open the moisture-proof packing and mount in a clean room environment (within ISO Class 7)
- Use the unsealed product (hereafter called “the product”) in an environment between 15 to 35°C, and within 45 to 75% humidity. Avoid using the product under any other conditions.
- Condensation may form on the chip surface in environments subject to sharp or sudden fluctuations in temperature, so avoid use in such locations. After the thermoelectrically cooled type is used by cooling, to prevent condensation on the chip surface, make sure that the product returns completely to room temperature before exposing it to air. Condensation on the chip surface can cause wiring corrosion or poor device characteristics or reliability due to ionization of substances adhering to the chip. In environments where the finished product is used, take measures to prevent condensation from forming on the chip.

### (2) General handling precautions

- Wear a mask and gloves, and handle the product with tweezers in a clean bench or a clean room and be careful not to contaminate the chip. If substances containing ions (such as sweat, fingerprints, saliva, etc.) adhere to the chip surface, then device reliability will deteriorate in the form of fluctuations in device electrical characteristics or poor photosensitivity.
- Take the product out of the moisture-proof package or desiccated atmosphere and mount it within 5 days.
- If the product comes shipped with a temporarily attached window (including protective tape), then after removing static electricity, detach the window just before using the product. This temporarily attached window cannot be reused.
- Applying excessive force to the product using a printed circuit board may cause the board to warp. This warping may damage the chip, wires, or bump connections so use caution.
- Do not let anything come in contact with the chip surface. Though the chip is hard, it is also brittle and easily notched. Sharp or hard items that come in contact with the chip may cause cracks or scratches, which can lead to fluctuations in electrical characteristics or poor device reliability. Treat any products that were dropped as defect parts and dispose of them.

### (3) Wire sections

- The photosensitive areas or light emitting areas are connected to their terminals using gold or aluminum wires only tens of microns in diameter. Never touch these wires. Even just gently touching these wires may cause problems such as shorts or wiring breaks due to warping.
- Even on the product where the wiring is protected, this protection is at best only for the purpose of relieving stress from wire warping when lightly touched. So never let anything come in contact with

---

protected wire sections.

#### (4) Removing contamination

- Use air-blow to remove contamination such as dust particles. When using air-blow, set the air pressure to a level as low as possible by taking effects on wire sections into consideration. Be sure to perform the air-blow work in a clean environment, such as clean room or clean bench. If the air-blow work is performed in a contaminated environment, dust particles may be entangled in an air flow and strike the device surface, causing damage to the device.
- If directly wiping the chip surface is unavoidable, then use a cotton-tipped swab moistened with ethyl alcohol and wipe gently while taking care not to touch the wire sections. Strongly rubbing the same section or wiping it over and over will cause poor electrical characteristics or a loss of device reliability.

For some products, wiping the chip surface is prohibited. If the products come with the precaution on the datasheets or delivery specification sheets, then be sure to strictly comply with the instruction.

- Never attempt wet washing.

#### (5) Sealing, etc.

Please observe the following precautions when sealing the product or bonding components such as scintillators to the chip section.

- If using resin sealers or adhesives, then use high purity material specifically for semiconductor in order to prevent contamination.
- If the chip surface is exposed during use, then be sure not to let condensation form on the chip surface.

## 3. Soldering

The correct soldering time and temperature differs depending on the type of package. Follow the soldering conditions established for each particular product.

#### (1) Points requiring special caution

- Take adequate care to make sure that the soldering iron tip temperature and the solder time are correct. Do not attempt soldering at high temperatures or long periods.
- Take measures to prevent solder or flux from flying outward and sticking to the chip surface, contaminating it.

#### (2) Flux

Use non-cleaning solder and rosin type flux. Using flux with relatively strong acid or alkali levels or inorganic flux will cause corrosion on the wire leads.

#### (3) When using a soldering iron

- To prevent effects from electrostatic charges, use a grounded soldering iron whose insulation resistance is 10 MΩ or more.
- Set the soldering iron tip temperature by referring to the recommended soldering temperature and soldering time conditions.
- Do not let the soldering iron directly contact the package section of the product. Direct contact with the soldering iron may cause mechanical or optical damage.
- Do the soldering so that no stress is applied to the package section of the product. Soldering in a

state where stress is applied will cause residual stress after the soldering that tends to cause deterioration.

[Figure 1] Soldering ceramic packages

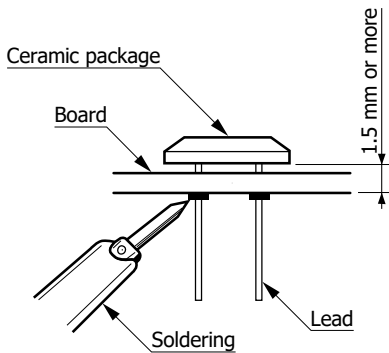

KPDC0013EF

[Table 1] Recommended soldering condition examples

| Package | Soldering temperature | Soldering time    | Remark  |
|---------|-----------------------|-------------------|---|
| Metal   | 260 °C or less        | Within 10 seconds |   |
| Ceramic | 260 °C or less        | Within 5 seconds  | Solder the leads at a point at least 1.5 mm away from the package body. |

#### (4) Soldering of bump connection products

- Use a solder paste suitable for components with fine pitch leads or terminals.
- Before making bump connections, design a process that takes into account factors such as the solder paste, underfill resin, temperature conditions, and warping of the board due to heating.
- If the packing was opened and the product left in that state for a long period of time, then oxidation will develop on the solder-ball surfaces, causing solder not to melt. So mount the device as quickly as possible after opening the packing.

## 4. Storage

Store all unsealed products as described below. Unsealed products are packed in a moisture-proof bag in the clean room before shipping.

| Parameter        | Storage method  | Cautions   |
|------------------|---|--|
| Unopened product | Temperature: 15 °C to 35 °C (normal temperature)<br>Humidity: 45% to 75% (normal humidity)<br>Period: within 3 months                 | A sharp item coming in contact with the moisture-proof bag might open a hole in it so use caution.               |
| Opened product   | Temperature: 17 °C to 28 °C (normal temperature)<br>Storage in a low-humidity desiccator (no condensation)<br>Period: within 3 months | After opening, we recommend storage in a low-humidity desiccator.<br>Avoid exposure to corrosive gases and dust. |

#### (1) Storage precautions

- The product is packed in a conductive moisture-proof bag prior to shipping. This bag helps prevent

---

oxidation or contamination on the terminal and moisture absorption by the package, so do not open this bag until just before product use. Even if still packed in the moisture-proof bag, do not let it get wet or be exposed to direct sunlight or harmful gases, or avoid turning off the night-time air conditioning to prevent the humidity from rising.

- Do not lay a heavy object or load on the product or the bag. Also avoid stacking the products or bags when storing them.
- Before storing, check that there are no objects in contact with the chip surface.
- If storing the product in another case, then use a container not easily charged with static electricity.

(2) Check for abnormal conditions when opening

- If there is a problem with the sealing of the moisture-proof packing, then the silica gel color will change from blue to red due to moisture absorption. So check for color change of the silica gel when opening.

## 5. Electrostatic sensitive devices

Electrostatic sensitive products come with an electrostatic warning label on the product packing. Handling of these products requires taking precautions on the following points to avoid damage and product deterioration due to static electricity.

[Figure 2] Electrostatic warning label

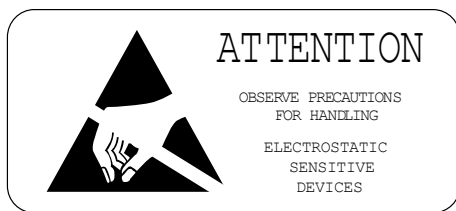

(1) Workplace and facilities, etc.

- Lay a conductive mat (750 k $\Omega$  to 1 G $\Omega$ ) on the surface of the workbench and ground it.
- Use conductive flooring material or lay a conductive mat on the workplace floor or and ground it.
- Ground all manufacturing equipment and inspection devices.
- Use a grounded soldering iron having an insulation resistance of 10 M $\Omega$  or higher.
- Keep moisture at approximately 50%. Low humidity tends to cause static electricity and high humidity is prone to moisture absorption.

(2) Handling

- Using an ionizer or similar item to eliminate electrical charges is recommended when handling the unsealed product.
- Wear anti-static clothing and conductive shoes (750 k $\Omega$  to 1 G $\Omega$ ).
- Attach a wrist strap (having protective resistance of 750 k $\Omega$  to 5 M $\Omega$ ) directly to the skin, and ground the strap. Also wear conductive finger sacks or gloves.
- Tools such as tweezers or soldering irons used to handle the product may sometimes become electrically charged. Connect a ground line as needed.
- If the product is induction-charged and contacts with a metal, excessive current may flow due to electrostatic discharge causing damage to the product. To prevent induction charging, keep objects (insulators such as plastic and vinyl, PC display monitors and keyboards, etc. that may possibly be

electrically charged) away from the product. The product may be induction-charged even by just bringing such objects close to the product. If keeping such objects near the product is unavoidable, then use an ionizer or similar equipment to remove electrostatic charges from the objects that are apt to be electrostatically charged.

- Friction on the product causes electrostatic charges. If such friction is unavoidable, then remove the electrostatic charges using an ionizer or similar equipment.
- Peripheral devices must be properly grounded so that no surges are applied to the product by a leakage voltage. Do not allow a voltage exceeding the absolute maximum rating to be applied to the product from the measurement instrument, etc. (This tends to occur during ON/OFF switching of power sources, so use caution.) If there is the possibility of a surge voltage, insert a filter (made up of a resistor and capacitor) to protect the unsealed product. During operation do not attach or detach any connector, etc. that are connected to the power supply line or output line.

### (3) Carrying, storage and packing

- Use a conductive carrying case and storage shelf.
- When storing the product, avoid placing it near equipment that may generate high voltage or high electromagnetic fields.
- When packing the product, short the electrodes to set them at the same potential and pack with a conductive material.

Note: It is not always necessary to provide all the anti-electrostatic and surge measures stated above. Implement these measures according to the extent of deterioration or damage that may occur.

[Figure 3] Electrostatic countermeasure example

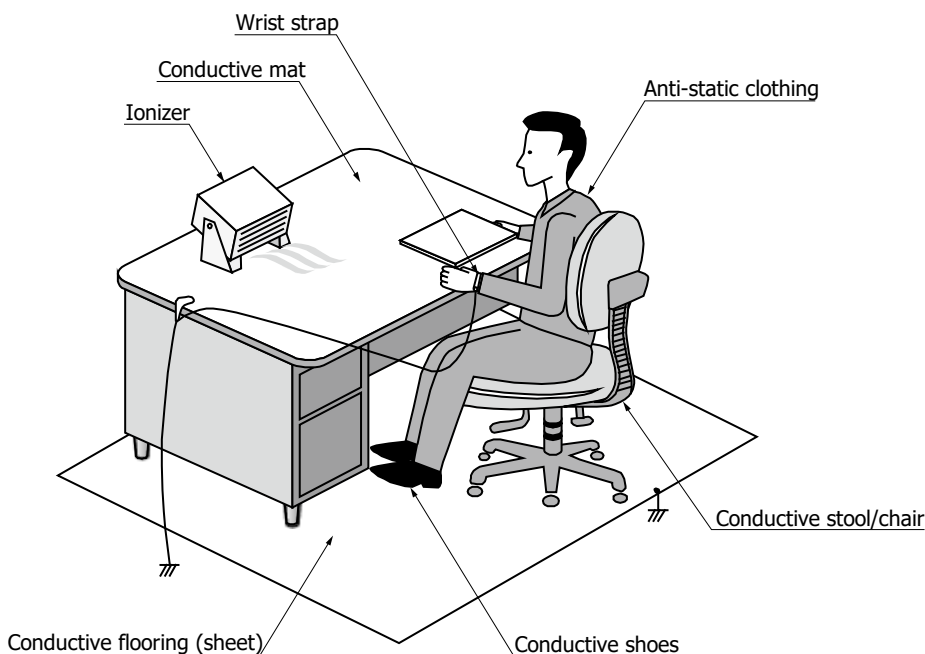

KOTH0031EB

## 6. Handling in cardboard boxes

The product comes shipped in cardboard boxes. When handling cardboard boxes, comply with warning labels displayed on the cardboard box.

[Figure 4] Warning displays on cardboard box

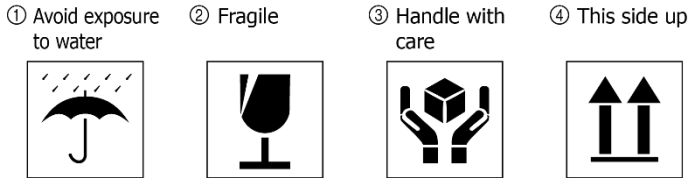

K0THC0030EB

## 7. Reliability testing

Reliability testing of unsealed products generally follows the standards shown below. The delivery specification sheets give detailed information about this testing.

| Item             | Method  | Frequency                      |
|------------------|---|--------------------------------|
| Reliability test | Reliability tests that comply with our standard conditions except for the drop impact, solvent resistance, and moisture resistance tests. | Sampling inspections as needed |

## 8. Warranty coverage for product breakdowns

| Item                 | Description   |
|----------------------|---|
| Warranty coverage    | Breakdowns in unsealed product due to our manufacturing process |
| No warranty coverage | Breakdowns due to the customer's mounting or assembly processes |

## 9. Handling of problem products

| Item                      | Description  |
|---------------------------|--|
| State of returned product | Problem products must usually be returned to us from the customer in the same state (not modified and mounted on board) as when first delivered from us. |
| Range of failure analysis | Generally, we bear no responsibility for failure analysis of problems outside the warranty coverage for unsealed product breakdowns.                     |